

Ballasted Rail Track Section with no Cant

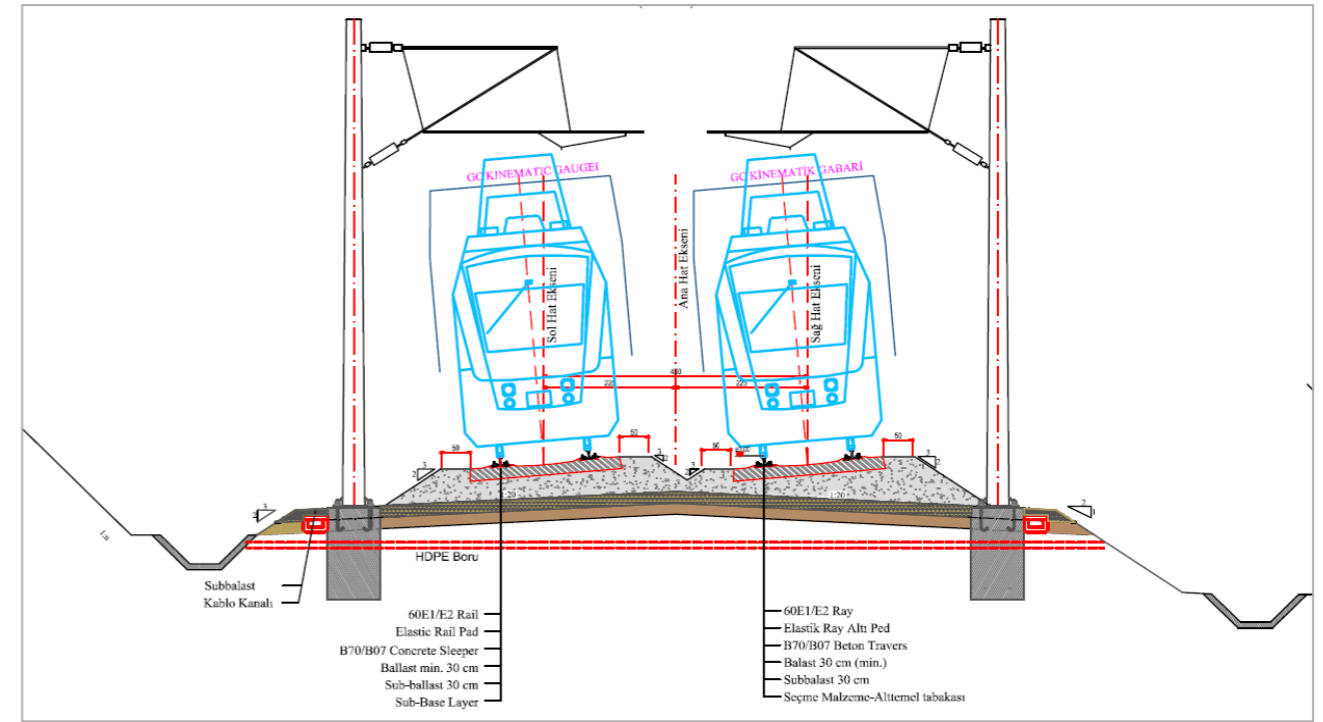

Ballasted Rail Track Section with Cant

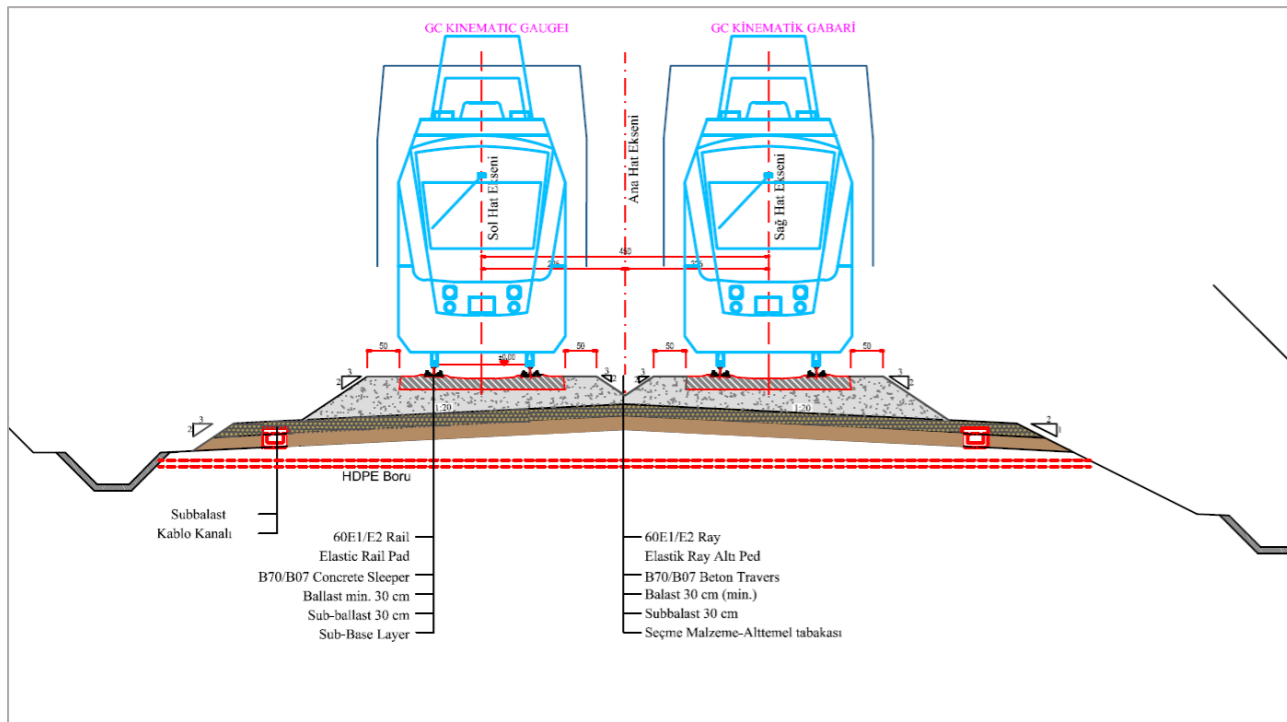

Ballasted Rail Track Section with no Cant, no Catenary

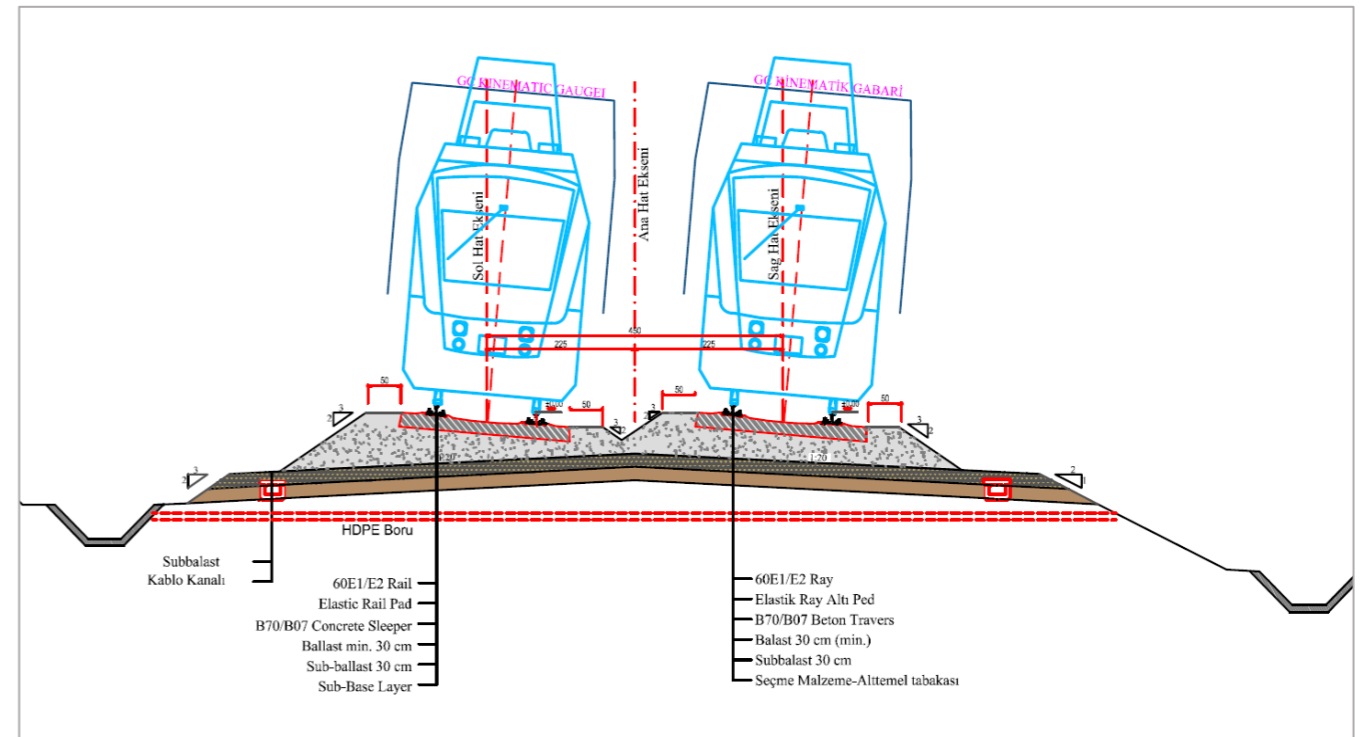

Ballasted Rail Track Section with Cant, no Catenary

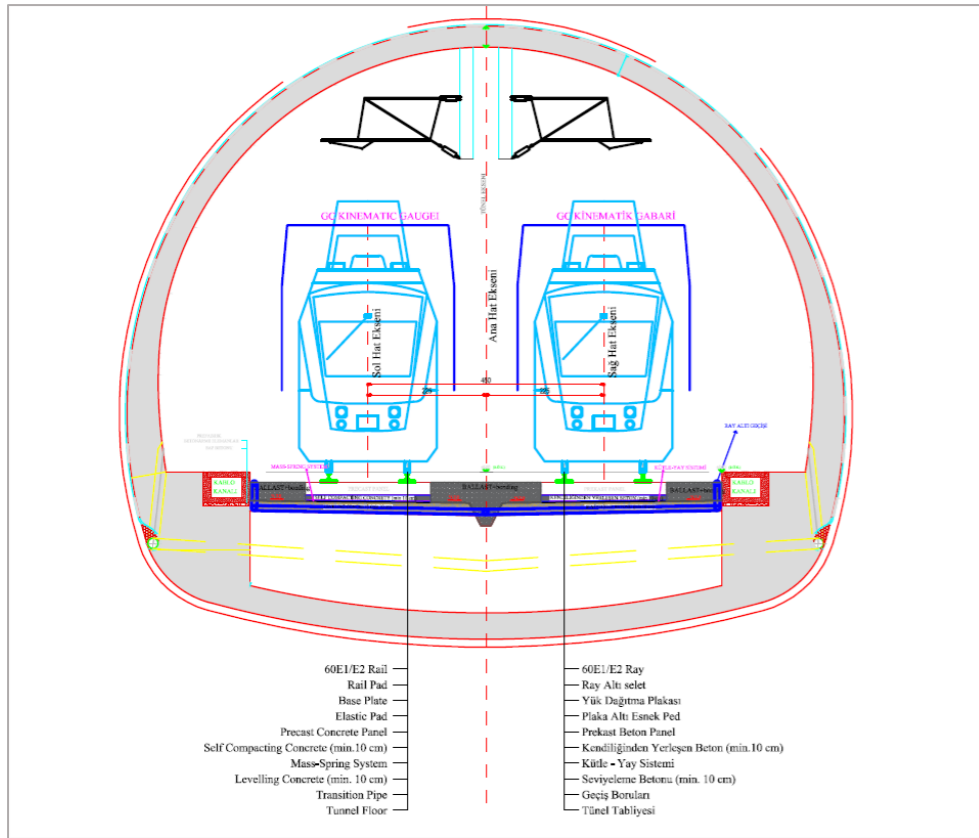

Rail Track Tunnel Section with no Ballast and no Cant

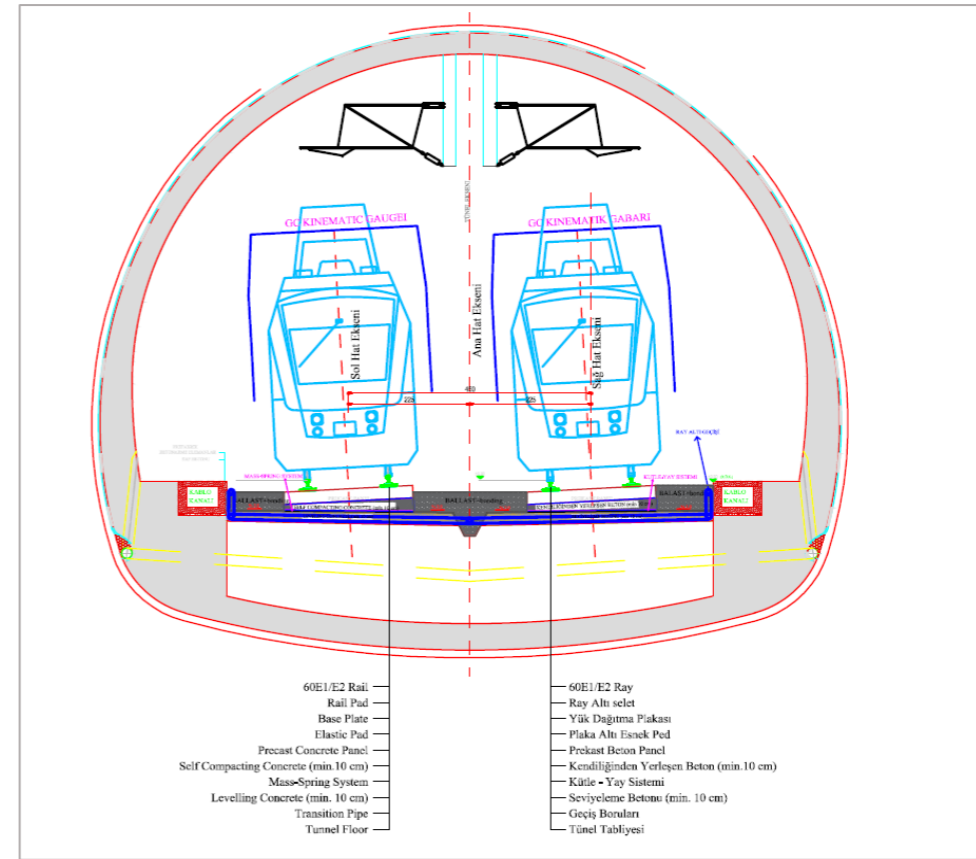

Rail Track Tunnel Section with no Ballast and with Cant

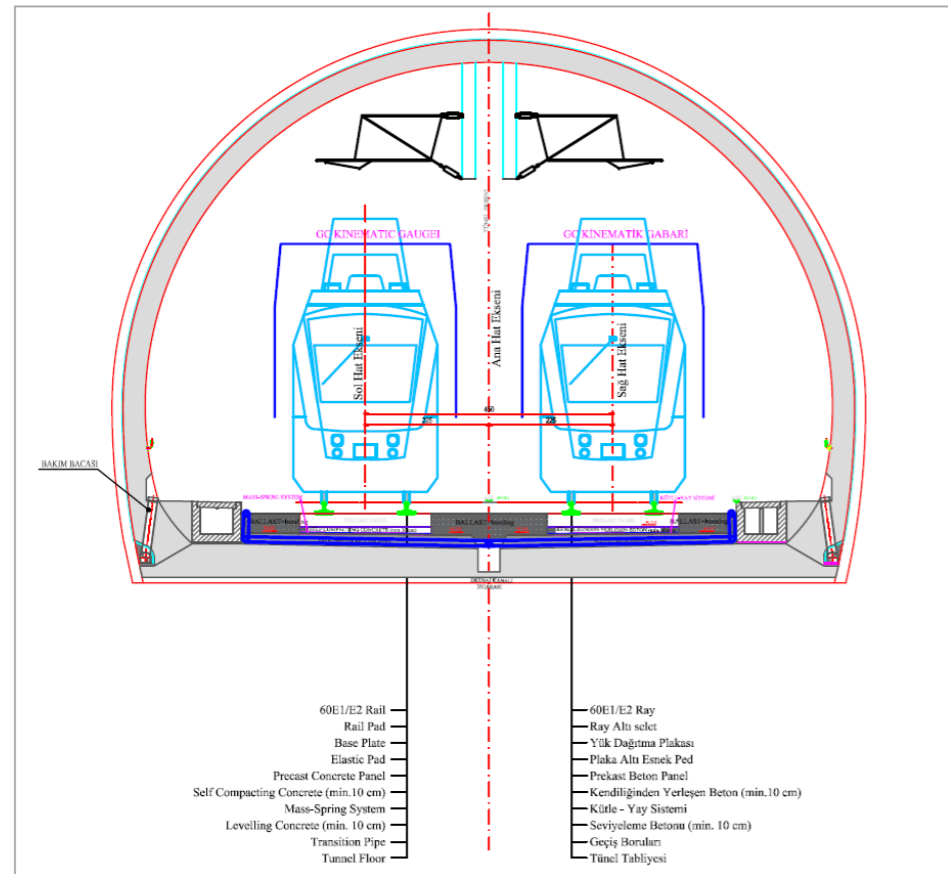

Rail Track Tunnel Section with Base Slab, no Ballast and no Cant

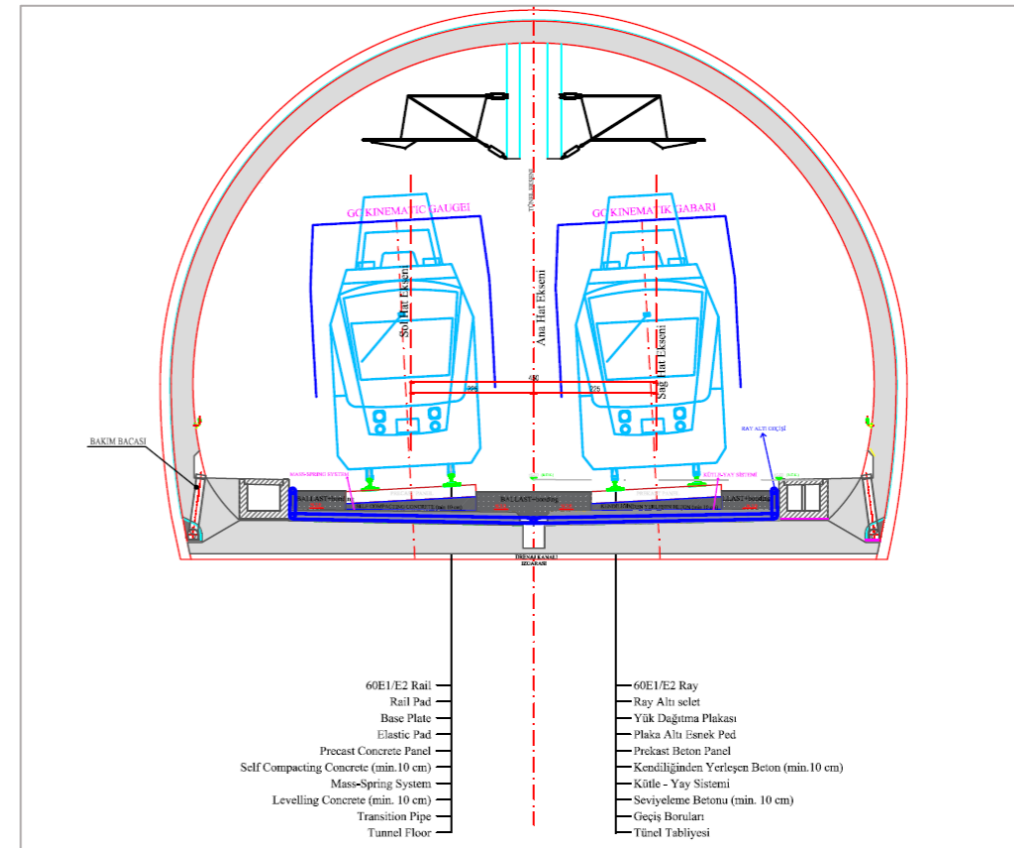

Rail Track Tunnel Section with Base Slab and Cant, no Ballast

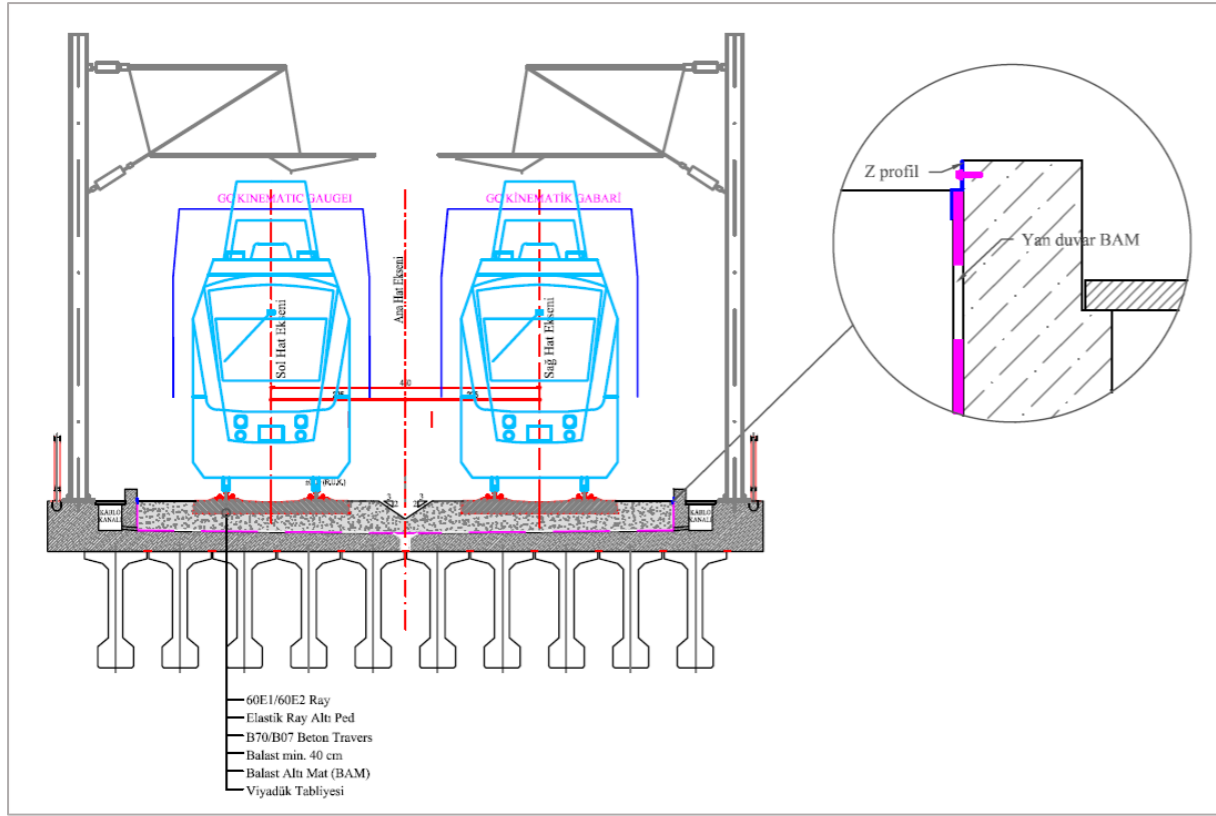

Ballasted Rail Track Viaduct Section with no Cant

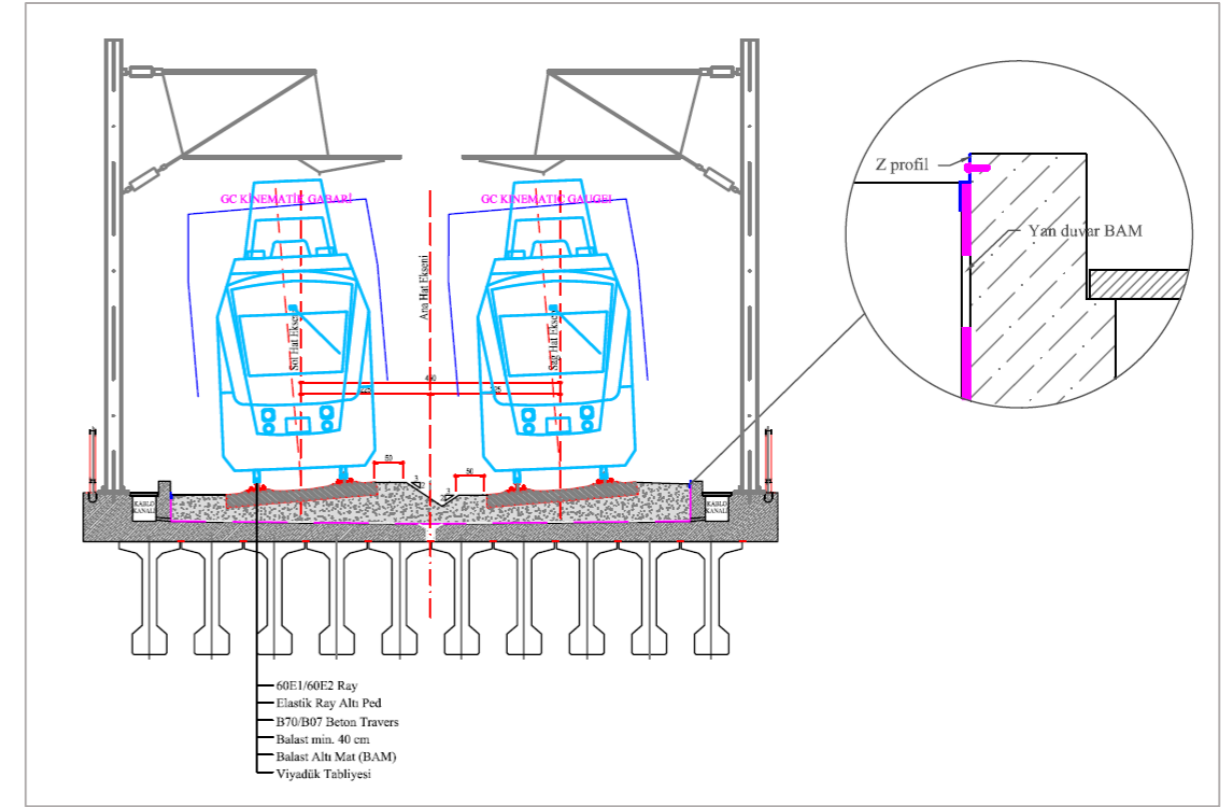

Ballasted Rail Track Viaduct Section with Cant

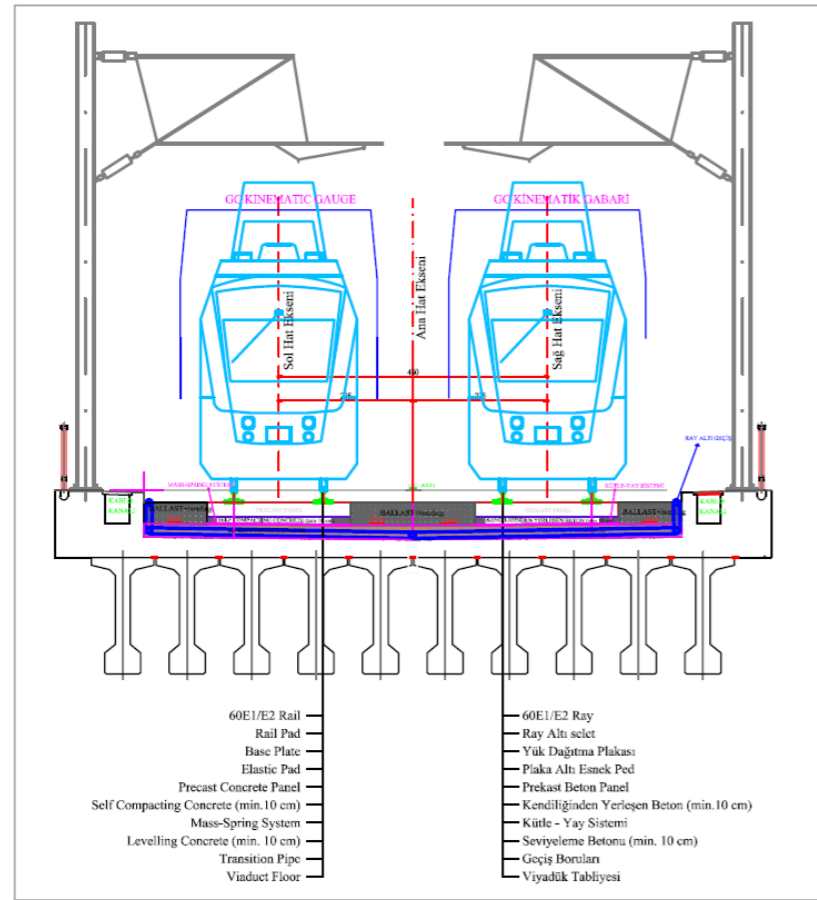

Rail Track Viaduct Section with no Cant and no Ballast

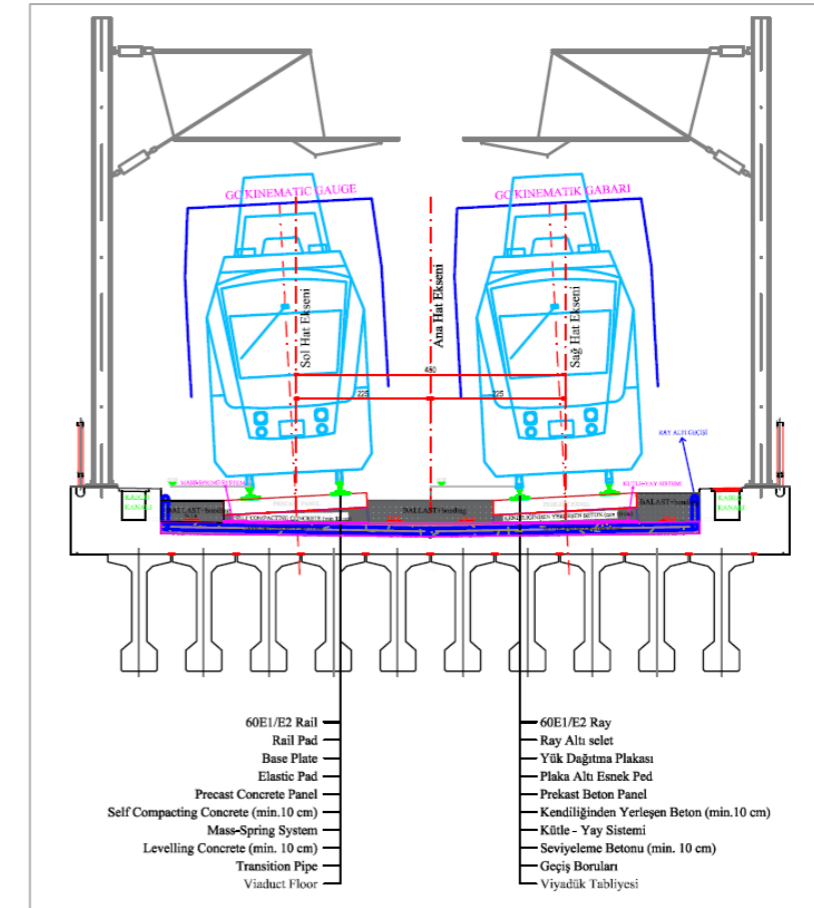

Rail Track Viaduct Section with Cant and no Ballast